



MOBRA™
TOP MOUNT CARGO DECK
CASTER

Where
Cargo Handling
Takes Flight

MOBRA

Top Mount Cargo Deck Caster

Ready for Takeoff

Mobra™ features an integrated mounting bracket with a precision cargo caster and built-in toe guard for reliable performance and enhanced protection. Designed for fast installation and easy replacement, it minimizes maintenance time while delivering a durable, cost-effective deck. The clean, enclosed deck design prevents debris from collecting underneath, keeping work areas cleaner and more efficient.

Features

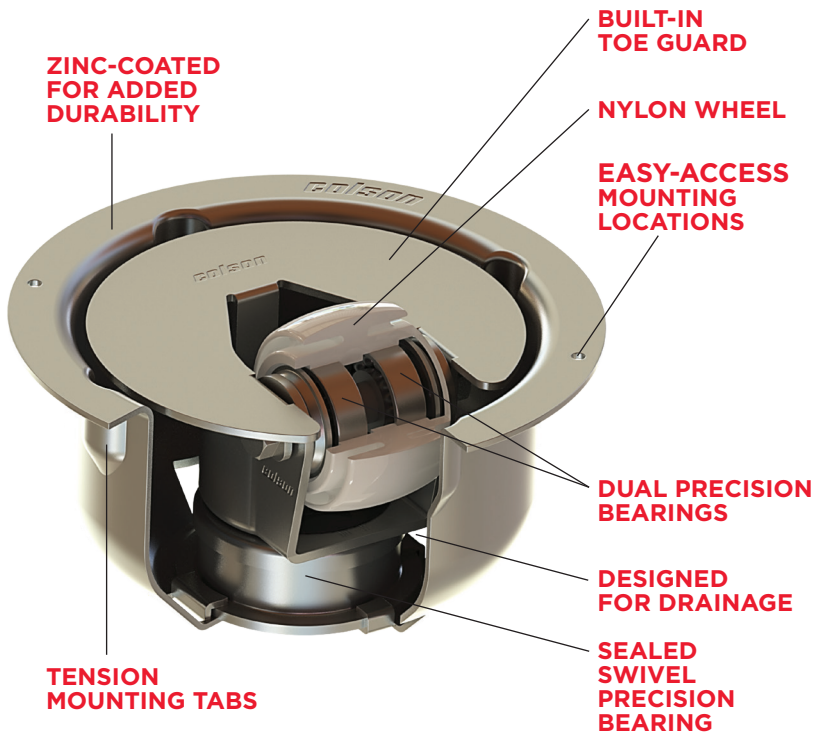

MODEL NUMBER: MBPN058MOBRA001

WHEEL DIAMETER: 58mm

TREAD WIDTH: 35mm

CAPACITY: 200kg (450lbs)

MOUNTING OPENING DIAMETER: 146mm (5¾")

MOUNTING CLEARANCE DEPTH: 84mm (3⅝")

Applications

- Aviation
- Cargo
- Automotive
- Conveyor Systems



Durability Testing

4X¹ THE STANDARD
WITHOUT FAILURE

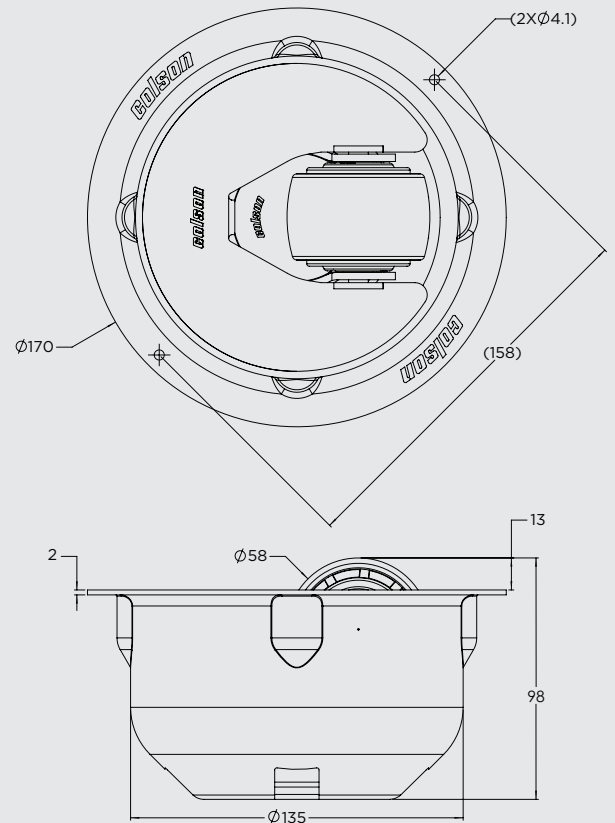

¹ Dynamic qualification tests conducted to qualify air cargo product in a Colson Group test facility. Test is based on ISO 22883 standard, modified for air cargo field usage. Products were durability tested at 200-kilogram load for 2.7 kilometers. Product was then removed from test and inspected. If there were no caster failures, the product test cycles were repeated until failure or after 4 tests completed. Mobra casters did not fail during testing and after completing dynamic test 4 times consecutively, testing was concluded. Testing at other facilities may vary due to equipment and flooring variables.